

ESTATE Rectangular Counter Table (HPL)
EST68



Protective cover available



• **NOT ACTIVATED** •
Suitable for rooftop



• **PREVIEW** •
regular items, suitable for more windy areas



Assembly



Partially handcrafted, random imperfections are part of the design



Adjustable

DIMENSIONS

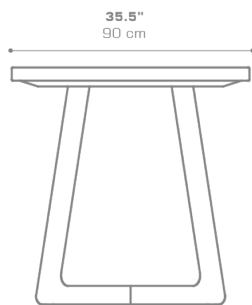
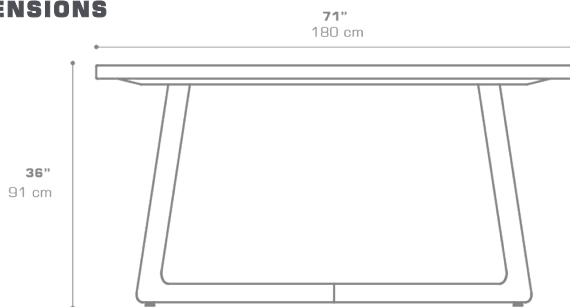

CONFIGURATIONS

FRAME : Premium Teak | Whitewash
TOP : High Pressure Laminate (HPL)

Protective Cover :
EST66PC Top table only
ESTPC-13 Table + 6 Counter Chairs

PACKING DETAILS

VOL : 20 ft³ | 0.56 m³
NW : 141 lb | 64 kg
GW : 176 lb | 80 kg
PU : 2 Boxes

DOWNLOAD MATERIALS

[Teak](#)
[HPL](#)

ADDITIONAL INFORMATION



6