

TITAN Side Table with Shelf 16" / 40 cm (Sintered Stone)

TITO4ST



• NOT ACTIVATED • PREVIEW •



Protective cover available

DIMENSIONS

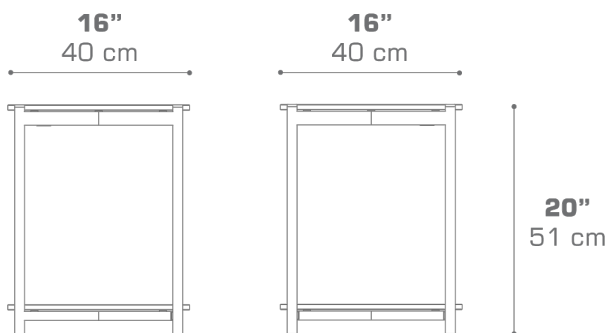

CONFIGURATIONS

FRAME : Powder Coating Aluminum
TOP : Sintered Stone

Protective Cover :
TITO4PC

PACKING DETAILS

VOL : 5 ft³ | 0.14 m³
NW : 24 lb | 11 kg
GW : 39.5 lb | 18 kg
PU : 1 Crate & 1 Box

DOWNLOAD MATERIALS

[Powder Coating Colors](#)
[Sintered Stone](#)