

MUNIA MO Curved Left Hand Modular System (Teak Top | High Back) MUN215H



Protective cover available



• NOT ACTIVATED • PREVIEW •
Floor mounting is included



Suitable for rooftop



Partially handcrafted, random imperfections are part of the design



Contains recycled parts, random imperfections are part of the design



Heavier than regular items, suitable for more windy areas

DIMENSIONS

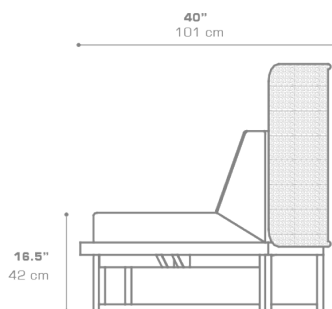
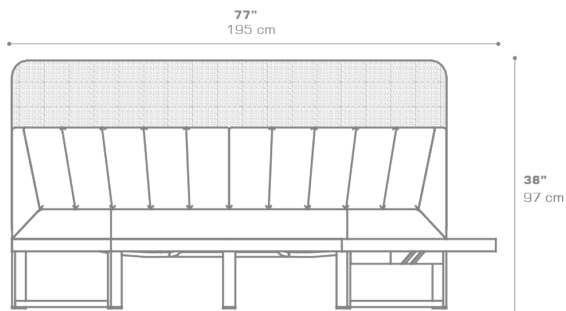

CONFIGURATIONS

FRAME	: Powder Coated Aluminum
SHELL	: Fiber Weave Flat Patterns
CUSHION	: Grade A B C D E
TOP	: Recycled Teak

PACKING DETAILS

VOL	: 76 ft ³ 2.15 m ³
NW	: 90 lb 41 kg
GW	: 139 lb 63 kg
PU	: 1 / box
COM	: 6.5 ly

DOWNLOAD MATERIALS

[Powder Coating Colors](#)

[Teak](#)

[Textiles](#)

[Weaving Flat Pattern](#)